



ZLM4 SECURITY MONITOR
Installation and User Manual



Edition 1, 2014



JVA ELECTRIC FENCE SYSTEMS



JVA ELECTRIC FENCE SYSTEMS

JVA products are designed by JVA Technologies, Queensland, Australia and distributed to:



JVA RSA SERVICE CENTRES

Bloemfontein

36 Kolbe Lane
Tel: 051 448 6695

Cape Town

Unit 15, Viking Business Park
Viking Way, Epping Industria
Tel: 021 534 5056

Centurion

74 Cantonments Road, Lyttleton
Tel: 012 644 0201

Durban North

Shop 11, Arcadia Centre
87 Umhlanga Rocks Drive
Tel: 031 563 0274/6478

East London

Shop 3, Paphos Park
Devereaux Avenue
Tel: 043 726 6652/60

East Rand (Jet Park)

Aerostar Business Park
219 Jet Park Road, Jet Park
Tel: 011 397 3507

George

Shop 3, 57 York Road
George
Tel: 044 874 0669

Kimberley

29 Schmidtsdrift Road
Tel: 053 861 5631

Nelspruit

D1 Waterfall Park
15 Rapid Street
Riverside Industrial Park
Tel: 013 752 7152

North Rand (Kya Sand)

174 Bernie Street
Randburg
Tel: 011 708 6442

Pietermaritzburg

51 Winston Road
Tel: 033 342 6727

Pinetown

Unit 1, 7 Suffert Street
Tel: 031 702 6351

Polokwane

19A Suez Street
Nirvana
Tel: 015 292 6273

Port Elizabeth

45 Mangold Street
Newton Park
Tel: 041 365 7178

Pretoria

1185 Steve Biko Road
(977 Voortrekker Road)
Wonderboom South
Tel: 012 335 4290

Rustenburg

1 Howick Avenue, Shop 7
Waterfall Mall
Tel: 014 537 2884

Somerset West

Shop 4, Broadway Centre
Urtel Crescent
Tel: 021 851 1978

Upington

Upindustria Business Park
4 Progressus Street, Upindustria
Tel: 054 332 1458

Vanderbijlpark

5 Prime Business Park
Vanderbijlpark
Tel: 082 783 8449

West Rand (Roodepoort)

602 Ontdekkers Road
Delaréy, Roodepoort
Tel: 011 472 8823

CONTENTS

INTRODUCTION	3
Features	4
Limitations	4
Equipment Requirements and Options	5
Requirements	5
Options	5
OPERATION	6
Status LED Lights	6
LCD display	6
ZLM4 LCD Screen	7
Control Options	8
Control Arbitration	8
Magnetic Proximity Switch	8
Control Inputs	8
Keypad Control	9
Keypad Versions	9
Arming/Disarming the Fence Using the Keypad	10
Keypad Status Display	10
When an Alarm Occurs	11
To Silence the Alarm	11
To Disarm	12
To Clear Alarm Memory	12
Changing your User PIN	12
Standby Battery	12
Internal Beeper/Keypad Beeper	12
ZLM4 Relevant Keypad Codes	13
SPECIFICATIONS	14
INSTALLATION	15
Installation Steps	15
Jumper Configuration	16
Fence Terminals	16
Control, Power and IO Terminals	17



- Wiring Diagrams 19
 - Standalone fence continuity monitor 19
 - Low Voltage Zoning System 20
 - Interconnecting Wiring Diagrams 21
 - Keypad Bus Wiring 22
 - Example Group Wiring Diagrams 23
- PROGRAMMING OPTIONS 24
 - Enter Programming Mode 24
 - To Exit Programming Mode 24
 - Changing the Installer PIN 24
 - Changing an Option 24
 - Programmable Options Table 25
 - Programming Options in Detail 27
 - Zone 1 Fence Voltage Alarm Level (01xx#) 27
 - Zone 2 Fence Voltage Alarm Level (02xx#) 27
 - Zone 3 Fence Voltage Alarm Level (03xx#) 27
 - Zone 4 Fence Voltage Alarm Level (04xx#) 27
 - Missed Pulse Count (06xx#) 27
 - Battery Alarm Voltage (07x#) 28
 - Siren on Time (08x#) 28
 - Siren Off Time (09x#) 28
 - Siren Cycles (10x#) 29
 - Input Type (11x#) 29
 - Input 2 Function (12x#) 29
 - Gate Entry/Exit Delay (13x#) 29
 - Chime mode (14x#) 30
 - Fence Mode (15x#) 30
 - Binary Options (16x#) 30
 - Auto Re-Arm time (20x#) 31
 - Relay Functions 31
 - Group Mode (26x#) 32
 - Keypad programming 33
 - Changing the Keypad Messages and Address 33
 - Keys Used for Changing Messages: 33
 - To Exit Keypad Programming 34
 - Connecting Multiple Keypads to a system 34
 - Notes Regarding Keypad Configuration 35
- WARRANTY 36

INTRODUCTION

The ZLM4 is a 4-zone, low voltage, electric fence monitor. The ZLM4 may be used by itself or in conjunction with a number of high voltage security electric fence energizers. The ZLM4 monitors up to 4 loops of fence wire, each up to several hundred meters long, to detect someone tampering with the fence by cutting or shorting the wires.

When used in conjunction with a high voltage electric fence energizer, the ZLM4 is wired to the non-energized earth wires on the fence. In this way, the ZML4 can be used to split one high voltage zone into up to 4 low voltage monitored zones for improved targeting of the response to potential security breaches.

The ZLM4 is compatible with the JVA Z series energizers. It may be connected via a keypad bus network with other Z series devices to enable the whole group to be controlled via one keypad, or linked to a PC running JVA Perimeter Patrol software.

The ZLM4 monitors a low voltage loop using intrinsically safe, isolated ELV DC. It employs a continuity check for detecting open circuits, DC voltage level sensing to detect a short to ground and pulse voltage sensing to detect a short to a line powered by a high voltage fence energizer.

The advanced features of this device allow the performance to be tuned to the fence and to the particular requirements of the site. This is done by adjusting the device's programmable options.

The ZLM4 will report an alarm on: detecting a low voltage loop cut (open circuit); shorted to ground (short); when high voltage from an electric fence energizer wire is shorted to the monitored low voltage loop; or when two low voltage loops short to one another (cross couple).

*An electric fence system
which meets current safety
regulations*



Features

- Monitors for continuity using safe 50V DC pulses
- Can be used to split a single security electric fence zone into up-to 4 low voltage zones
- Can detect a short, cut or if the monitored wire is touching a high voltage wire
- Optional LCD display, displays which zone is in alarm and other information
- Controlled and programmed via a JVA keypad with similar codes to the JVA Z series
- Compatible with all JVA Z series network adaptors including:
 - USB
 - Able to be monitored via PC (using Perimeter Patrol software version 5.3 or above)
 - RS485
 - TCP/IP *not all versions
 - GSM *not all versions
 - Able to be integrated into third party access control and security information management systems at a variety of levels
- Enables the construction of systems from economical key switch operation to complex PC controlled applications
- Built into the wall mountable Z series energizer enclosure
- Runs from 16Vac or 12V DC external source
- Built-in battery charger for optional 7aH back up battery
- Siren and Strobe switched 12V DC outputs for standalone operation
- 2 control inputs and 4 form C relays with many programmable functions for low level integration with other systems
- Fence connections are fully isolated from power and IO as per relevant parts of ICE60335.2.76

Limitations

- Any energizer used with the ZLM4 must comply with the IEC60335.2.76 electrical safety standard.
- Energizers with a negative voltage pulse may not be suitable.
- The energizer output pulse energy must not exceed 18 Joules.
- The maximum series resistance of the fence wire loop which can be accurately monitored is 5000 Ohms.
- Not all versions of the PAE212, PAE224 or PAE218 GSM module recognize the ZLM4. For compatibility please check with your distributor or JVA.
- The JVA LCD keypad (PTE0210) requires version 2.12 or later firmware to operate with a ZLM4. The keypad firmware can be viewed at power up or by pressing *9# on the keypad.
- Perimeter Patrol version 5.2.2 or later is required to operate with a ZLM4.

Equipment Requirements and Options

Requirements

- 12V rechargeable backup battery or external 12V source
- 16Vac or 24Vdc power adaptor if using internal rechargeable battery

Options

- 12V Siren and strobe light
- LCD keypad (PTE0210). Note 1,2
- Windows PC
 - Windows XP or later
 - PAE223 or PAE100 serial adaptor AND USB to serial adaptor
 - or PAE212 TCP/IP adaptor
 - Perimeter Patrol PC application

NOTES:

1. While the keypad is not essential for normal operation, it is required to adjust the programmable options.
2. Up to 3 keypads may be connected in parallel on a ZLM4. Each keypad must have a unique ID setting.
3. The ZLM4 contains patent pending technology. Contact JVA SA for more information.

For more information please see www.jva-fence.com.au.

OPERATION

Status LED Lights

The status LED's on the front of the ZLM4 allow the user to ascertain quickly the current status of the unit and if any action needs to be taken. Below is a brief description of each LED (top to bottom) and the information it conveys.

Power	–	On (Green) whenever the unit has power
Armed	–	On (Red) when the unit is armed; flashes if any zone is bypassed
Fence	–	On (Red) when there is a fence alarm (any zone); flashes if any zone has a low voltage
Gate	–	On (Red) when there is a gate alarm; flashes if the gate is open
Status	–	Flashes (Red) an error code for service errors; the LCD may also show an error message

Status LED Number of Flashes	Interpretation	Corrective Action
1	Not used	
2	16Vac Mains fail	Restore mains power
3	Low battery, bad battery	Charge or replace battery
4	PCB service fault	Return to repair/service centre NOTE: A Z slave will show this error if disconnected from the Master

LCD Display

The Optional LCD display shows the status of the ZLM4 at all times.



ZLM4 LCD Screen

The ZLM4 will show the status on the optional LCD display.

When disarmed:

JVA ZLM4
Disarmed

While armed, the LCD display cycles the following information:

1: 35V 2: 37V
2: 40V 4: 35V

ZLM4 Armed
All clear

Battery 14.5V
AC On

Pressing # on the keypad will freeze the current information displayed on the LCD screen for approximately 10 pulses. Pressing the # key again will cycle the display to the next information screen.

When an alarm occurs, the screen will detail the type of alarm and the sector if applicable.

Alarm: Zone 1
Gnd Short

Alarm: Zone 2
Fence Cut

Alarm: Zone 3
HV Short

ALARM
Gate

ALARM
Energizer Fail

Various 'troubles' are also displayed, such as AC fail or low battery.

Battery 11.5V
AC Fail

When the ZLM4 is disarmed, all current alarms are shown.

JVA ZLM4
Disarmed

Alarm: Zone 1
Gnd Short

The display also shows the programmable options and values when in programming mode.

1: Alarm V 1
Value: 20

Control Options

The ZLM4 may be armed and disarmed (controlled) using a:

- Magnetic proximity fob
- Key switch or remote switch connected to the control input (IN1)
- Remote control radio receiver connected to IN1
- Z Series Keypad (LCD or Touch)
- JVA Webserver *not all versions
- JVA GSM module *not all versions
- Windows PC running JVA Perimeter Patrol software
- Low level interface (wired to control inputs and relay outputs) from a third party security alarm panel or Physical Security Information System (PSIM).

NOTE: More than 1 method may be used in the one installation.

Control Arbitration

If an installation contains two ways to control the ZLM4, then the most recent control signal will determine the Armed/Disarmed state. For example if the ZLM4 is armed via the keypad and then disarmed at the control input (IN1), it will disarm.

The higher level control methods such as the Webserver, GSM and PC control software may override the Control Input and Keypad's methods, depending on the options used. If you need to make sure that the fence is disarmed (for maintenance), then using the key switch or keypad alone may not guarantee that the fence will remain disarmed.

Magnetic Proximity Switch

The ZLM4 may be controlled using the JVA Permanent Magnet Key Ring Fob. To operate, the fob must be held against the control zone marked on the front label. The energizer will beep and toggle from armed to disarmed or visa versa after the fob is held in position for 2 seconds. The Magnetic Proximity Receiver should be disabled in the programmable options if it is not being used.

Control Inputs

The ZLM4 may have a single key switch mounted on the right hand side of the cabinet which may be used to arm and disarm the security electric fence to which it is connected. This switch is useful for the simplest implementations where no keypad or PC control program is used. It may be disabled by the installer by removing the lead from socket J2.

When switched on via the key switch (or a switch connected to IN1) the ZLM4 will power up the energizer to which it is coupled and begin monitoring the fence.

The screen will change to display the *Armed* status and any faults or alarms. If there is a fence fault the ZLM4 will go into alarm, the internal beeper will sound (if it has not been inhibited) and any siren and strobe connected to the ZLM4 will be turned on.

The zone in which the fault has occurred will be displayed.

Switching the key switch off will disarm the ZLM4, though it will continue to display the last alarm and zone.

Keypad Control

The ZLM4 uses the same keypad as the JVA Z series energizers and is controlled using similar keypad codes.

The PTE0210 keypad (Version 2.00 and higher) will display the Fence voltages plus the Zone if in fence alarm.

Alarms and troubles will also be displayed.

The keypad has two LED lights:



Power	On with Mains power, Off with Main fail, flashes on low battery
Armed	On when the energizer is armed, flashes when in low power mode

All other indications are given via messages on the keypad LCD screen.

If the keypad shows *Alarm* or *Trouble*, pressing [#] will reveal more information about the problem.

NOTE: There is no panic function currently implemented.

Keypad Versions

The current version keypad is a PTE0210 with code version 2.00. Older versions have limitations.

The keypad version can be seen by pressing *9#.

- PTE0200** Shows *ALPHA KEYPAD Revision 7.0*
- Cannot show Zone (fence) voltages
 - Shows only Zone alarms 1-8
 - Does not show Gate alarms

PTE0210 Shows *PTE0210* and the code version.

- Can show fence voltages
- Will respond to *68# to analyse the 'group'.
- Version 1.21 and below
 - Older version, can be upgraded to V2.00 firmware
 - Cannot detect or operate with the ZLM4
- Version 2.20 and higher
 - ZLM4 is supported, zones are displayed

PTE0230 Android Based Touch Screen Keypad

- Provides the most advanced monitoring and control of all Z range devices
- All functions are available
- Refer to the inbuilt help; the rest of this chapter refers to the simpler LCD keypads above.

Arming/Disarming the Fence Using the Keypad

Enter your User PIN (Personal Identification Number: four digits long) and push the # key. Make sure the red ARM light comes on and the keypad beeps twice to confirm that the system is armed.

The fence will power up and if all is well (no faults) the system will be ready to deter and detect.

To disarm the system enter your User PIN and press #.

NOTE: If there is an alarm sounding you will need to enter your PIN twice: once to silence the alarm and once more to disarm.

See also the section on Programming Keypads (page 33).

Keypad Status Display

In normal operation the keypad shows a continuous summary of the system status. For example, if the system is disarmed the keypad will display *Ready to Arm*.

If the system is armed then the keypad will display the voltages for each zone in the system.

Since there can be many things to display, the keypad automatically 'scrolls' through all relevant detail. Each screen is shown for about 2 seconds. If you wish to hold the display at a particular point, simply press the [#] key. The auto scrolling will stop for about 20 seconds.

Pressing the [#] key again will advance the display one step.

If a new 'trouble' (AC fail, low battery etc.) or alarm occurs, the keypad screen will jump to the relevant zone, the keypad will beep (unless toggled off) and auto scrolling will cease for about 3 minutes.

When an Alarm Occurs

An Alarm will occur if there is a fault on the fence caused by a short or an open circuit (cut), while the system is armed. The siren will sound and the strobe will light. The internal beeper and the keypad may also sound, depending on how your system is configured.

There are 3 ways the ZLM4 can detect a fence fault:

- 1) A low voltage circuit is cut (open circuit)
- 2) A low voltage circuit is shorted to ground (LV short)
- 3) A high voltage wire shorts to a low voltage wire (HV Short).

The siren and keypad beeper will sound and any relays assigned to this fence alarm will turn on.

An alarm will also sound if Control Input 2 is assigned to the *GATE* function and the gate input is opened for longer than the Gate delay time.

After the siren has cycled on and off according to the times and numbers set in options, the siren will stop sounding. The on and off timing can be set in the programmable options. The Strobe will remain on. After a further delay (Auto Rearm Time) the siren will again respond to the next alarm condition with a new set of on/off cycles.

If the alarm condition is removed, the siren will stop after the end of the current *On Time* (Siren On Time).

If the siren is silenced (by entering PIN#), the siren will enter the next *Off Time Cycle* (Siren Off Time). If the alarm condition is still present (voltage is low) the siren will sound again after the preset *Off Time*. If the alarm condition is not present, the energizer is instantly rearmed, irrespective of the *Auto-Rearm* setting.

To Silence the Alarm

If there is no keypad attached, simply disarm the ZLM4 using the key switch or magnetic fob.

Using a keypad, enter your User PIN and press #. This will silence the alarm but not disarm the system; the armed light will still be on. The system will be ready for the next alarm.

NOTES:

1. This silence function will not operate if the ZLM4 is part of a Z series networked group.
2. The last alarmed Zone will still be displayed on the front panel LCD and the keypad.
3. The siren and strobe are ready to respond again if triggered.

To Disarm

If there is no keypad attached, simply disarm the ZLM4 using the key switch or magnetic fob.

Using a keypad, disarm the system by entering your User PIN and press #.

The Fence or Gate light on the ZLM4 will remain on to show the Alarm Memory. This can be cleared by entering the *Clear Alarm* memory command *1#. The alarm memory will also be cleared when the ZLM4 next arms.

To Clear Alarm Memory

After an alarm occurs, pressing *1#, will clear the Alarm Memory. If the problem still exists the unit will alarm again.

Changing your User PIN

Enter the current 4 digit PIN and press *0#. This enters User Programming mode.

Enter your new PIN (must be 4 digits) and then #.

Press *# to exit User Programming mode.

Make sure your new PIN works by using it to arm the energizer.

The default User PIN is 1234.

For example, the following keypad sequence will change the User PIN to 8015 from the default PIN: 1 2 3 4 * 0 # 8 0 1 5 # * #

Standby Battery

Should there be a loss of mains power, the *Power* light on the keypad will go off. The status LED on the ZLM4 front panel will flash twice and the keypad will show *TROUBLE – AC FAIL*.

If the loss of power is prolonged, the battery may become discharged and ineffective. The Power light on the keypad will start to flash indicating that the battery charge is low. The status LED on the ZLM4 front panel will flash three times and the keypad will show *TROUBLE: LOW BAT*.

If the standby battery requires replacement, the Status LED on the energizer will flash 3 times even after the mains power has been restored.

Internal Beeper/Keypad Beeper

Depending on the Chime Mode setting, the internal beeper and keypad beeper will sound when there is a fence alarm, a gate alarm, a general alarm or a door chime. On flat battery the keypad will always beep 4 times before the energizer automatically enters low power mode to preserve the battery. On *AC fail* it will not beep.

NOTE: The Internal beeper also beeps at power up.

ZLM4 Relevant Keypad Codes

Function	Key Sequence
Arm/Disarm	[User PIN][#]
Silence an alarm (Single zone system only)	[User PIN][#] Note 1
Start programming the Z series energizer	[Installer PIN][*] [0] [#]
Start programming the keypad	[Installer PIN][*] [0] [1] [#]
Exit programming (any mode)	[*] [#]
Change a user PIN, 4 Digits	[User PIN][*]0[#][New PIN]#
Change the installer PIN, 5 Digits	[0] [0] [New Installer PIN][#] Note 5
Arm all zones (Multi-zone groups)	[User PIN][*][1][0][#] Note 2
Arm Zone 1 (Master)	[User PIN][*][1][1][#]
Arm Zone X, where X is any zone number up to 15	[User PIN][*][1][x][#]
Disarm All Zones	[User PIN][*][2][0][#]
Disarm Zone 1 or Master	[User PIN][*][2][1][#]
Disarm Zone X, where X is any zone number up to 15	[User PIN][*][2][x][#]
Switch to low power mode (all zones)	[User PIN][*][4][1][#]
Switch to high power mode (all zones)	[User PIN][*][4][2][#]
Arm gate circuits only	[User PIN][*][4][#] Note 7
To change the keypad messages to English	[*][3][1][#]
To change the keypad messages to Spanish	[*][3][2][#] (not well supported yet)
Keypad Audible Feedback On/Off	[*] [5] [1] [#]
Keypad Chimes On/Off	[*] [5] [3] [#]
Keypad Error Tones On/Off	[*] [5] [4] [#]
Local Keypad Alarms On/Off	[*] [5] [5] [#] Note 8
Backlight mode On/On with keys/Off	[*] [8] [#]
Display keypad model	[*] [9] [#]
Re-analyse the group	[*][6][8][#]
Reset and display firmware version number	[User PIN][*][6][8][#] Note 3
Reset and return to factory defaults	[Installer PIN][*] [6] [8] [#] Note 6
Power Boost	[*] [9] [9] [#] Note 3
Siren Test	[*] [6] [3] [#] Note 3
Battery Test	[*] [6] [4] [#] Note 3
Clear alarm memory	[*] [1] [#] Note 4

SPECIFICATIONS

The specifications table below outlines the power consumption of the ZLM4 and the acceptable voltage and current ranges for different inputs and outputs.

Internal battery charger float voltage	14.2Vdc
Internal battery charger charging current	1200mA
Power consumption of ZLM4 (Note 1)	130mA at 12.5 Vdc
Maximum AC input voltage when internal battery charger is supplying 580mA	19Vac
Battery backup time (without keypad)	24 Hours
Maximum voltage on In1, SW2 and Gate inputs (Note 2)	5Vdc
Maximum power available from Siren and Strobe outputs (Note 3)	35Watts (2.5A at 13.5V)
Maximum energizer Joules (Note 4)	18J
Maximum low voltage loop impedance	5000 Ohm
Maximum loop capacitance to ground	0.2uF

NOTES:

1. This is the power consumption when none of the powered outputs are active and the keypad is not connected. The rated power consumption may be lower depending on relay configuration and alarm states.
2. The control inputs are supplied with 5V from a weak pull up circuit so that they can be controlled by using dry contacts from a relay or switch. A device with 'open collector' outputs may be used. They can also be driven from a 5V switched output, as long as the driving circuit actively pulls down to ground when off.
3. This is the limit for the combination of the loads on both the Siren and Strobe outputs.
4. This is the maximum rating of the energizer if the ZLM4 is used on the same fence as a high voltage electric fence energizer. Beyond this rating the ZLM4 loop circuit protection MOV's may fail if high voltage wires are shorted to the ZLM4 loop wires.

INSTALLATION

It is recommended that all installations are performed by qualified technicians.

Installation Steps

1. Read the entire ZLM4 and Energizer manuals first!
2. Design and build the fence. (Beyond the scope of this manual.) Ask your distributor for help if required.
3. Decide where the energizer, ZLM4 and keypad are to be mounted. If on an external wall it should be housed within a weatherproof equipment box, shaded from direct sun.
4. Remove the lid of the ZLM4 using a 5mm Hex key.
5. Remove the ZLM4 PCB chassis from the housing by removing the two screws at the top corners.
6. Mount the housing by using 4 screws through the rear of the box. The box must be mounted to a wall in such a way that all of the 4 holes in the rear of the case are against the mounting surface.
7. Replace the PCB chassis.
8. If using a keypad, remove the rear housing of the keypad and fix it to the wall.
9. Wire the low voltage cables to the PCB terminals.
10. Wire the high voltage cable to the PCB terminals.
11. Set the Jumpers as required.
12. Fit the battery leads to the battery. The Error LED should be blinking twice to show mains fail.
13. Replace the front cover (lid).
14. Turn AC power on.
15. Arm the ZLM4 and switch on the energizer if used. The LCD display will now show the zone voltages.
16. Find and remove any faults on the fence.
17. Test that a short in any zone puts the ZLM4 into alarm and shows the correct Zone.

Jumper Configuration

The ZLM4 is equipped with three jumpers, two of which (J3 and J4) operate in an identical fashion to those on other Z-range energizers. The third jumper, J8 will suppress the beeper on the ZLM4 when fitted.

These are located in the top left corner of the PCB.

Jumper	Function	Purpose
J3	Inhibit Mains fail error	J3 is fitted to inhibit Mains fail errors if the intention is to operate the energizer on DC only (as in solar power systems).
J4	Factory default jumper Off to return programmable options to factory defaults on power up	If the energizer needs to be defaulted to factory settings, remove all power (AC and battery) and remove the J4 jumper. Reapply the mains and the battery power. Reapply the J4 jumper and the energizer will be reset to default settings.
J8	Inhibit internal Beeper	Fitted to inhibit the internal beeper, irrespective of any option setting

Fence Terminals

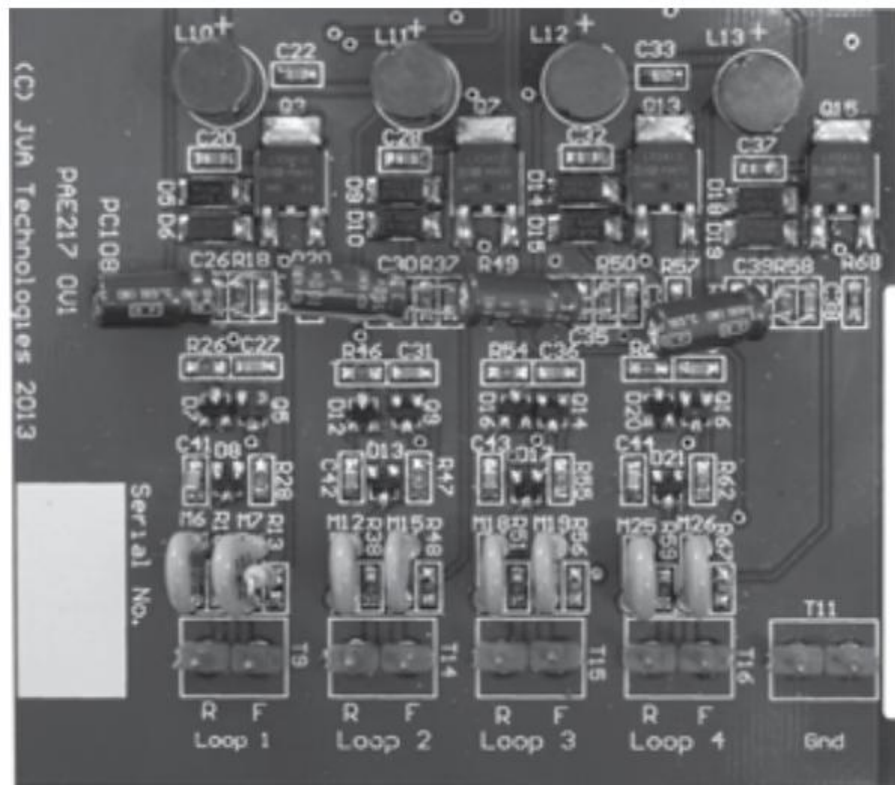

Description of fence terminals (left to right in the illustration on the previous page)

Loop 1	Connect to zone 1 fence wires
Loop 2	Connect to zone 2 fence wires
Loop 3	Connect to zone 3 fence wires
Loop 4	Connect to zone 4 fence wires
Ground	Connect to main fence earth stakes.

Control, Power and IO Terminals

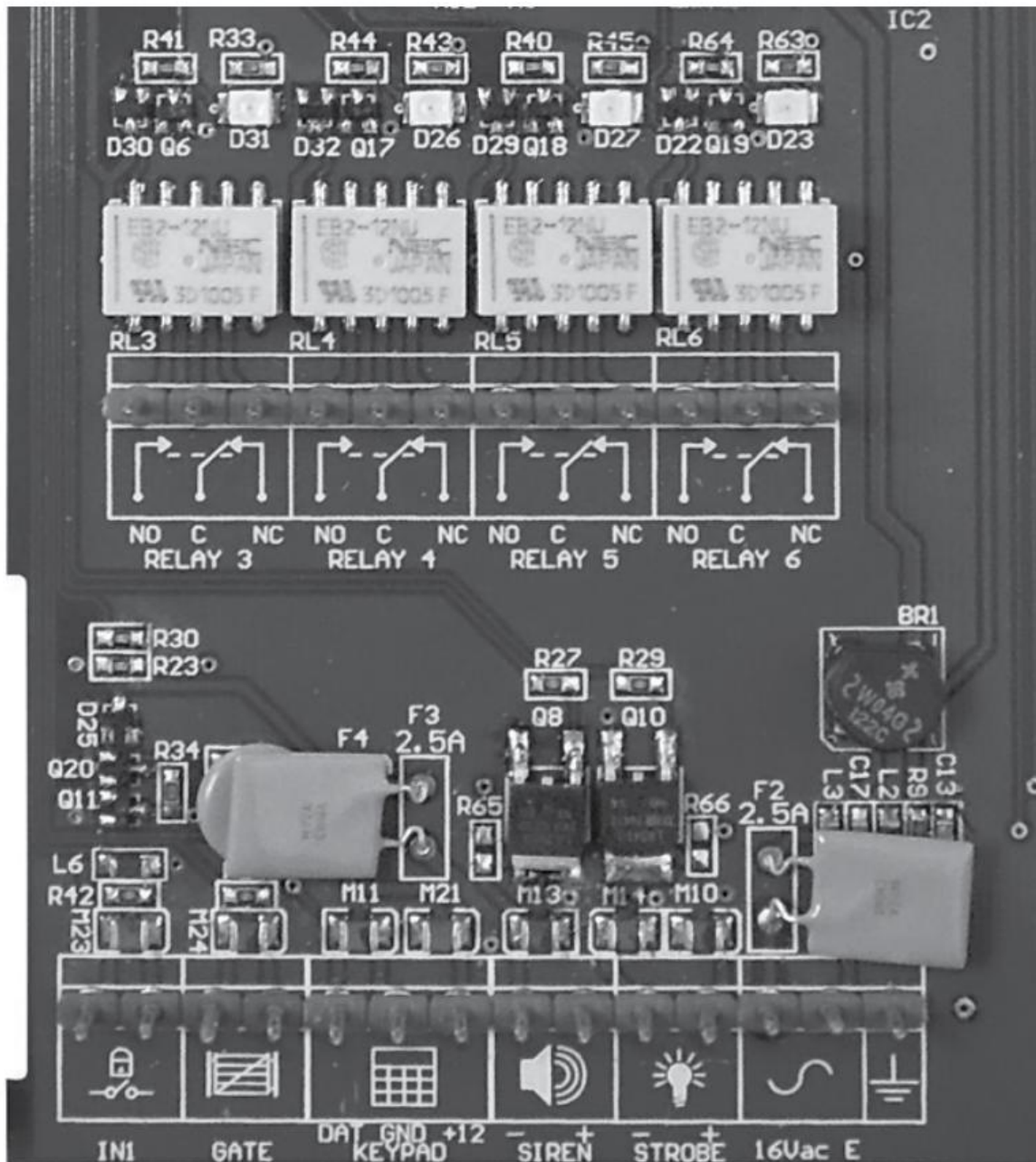

Installation

Description of control, power and IO (Input, Output) terminals

Label	Type	Description
<i>IN1</i>	2 Way	Energizer control input (dry contact) Defaults to normally open Can be used for a remote switch or a radio receiver The receiver may be powered from the keypad +12V terminal.
<i>Gate</i>	2 Way	Energizer control input Defaults to normally open low power but may also be assigned to gate input When the unit is armed and the gate is opened, it will trigger the gate alarm.
<i>Keypad</i>	3 Way	Supplies power and data line for an external keypad The +12V source on these terminals is protected by 1A self-resetting fuse.
<i>Siren</i>	2 Way	Switched 12 volt output Low side switched 35W max (including strobe) A buffer relay should be used when connecting these outputs to an alarm panel.
<i>Strobe</i>	2 Way	Switched 12 volt output Low side switched 35W max (including siren) A buffer relay should be used when connecting these outputs to an alarm panel.
<i>AC IN</i>	3 Way	16Vac power input Fused via F3 3A self resetting fuse The Earth terminal may be required to be connected to mains earth in some countries: consult your local wiring guidelines.
<i>Relay 3</i>	3 Way	May be set to any of 16 alarm conditions Defaults to zone 1 alarm
<i>Relay 4</i>	3 Way	May be set to any of 16 alarm conditions Defaults to zone 2 alarm
<i>Relay 5</i>	3 Way	May be set to any of 16 alarm conditions Defaults to zone 3 alarm
<i>Relay 6</i>	3 Way	May be set to any of 16 alarm conditions Defaults to zone 4 alarm

Wiring Diagrams

Standalone Fence Continuity Monitor

The ZLM4 may be used to monitor a loop of wire on or under a perimeter fence.

- Bare conductors on insulators as per high voltage electric fence, but powered by the ZLM4 low voltage monitor for sensitive environments such as public areas

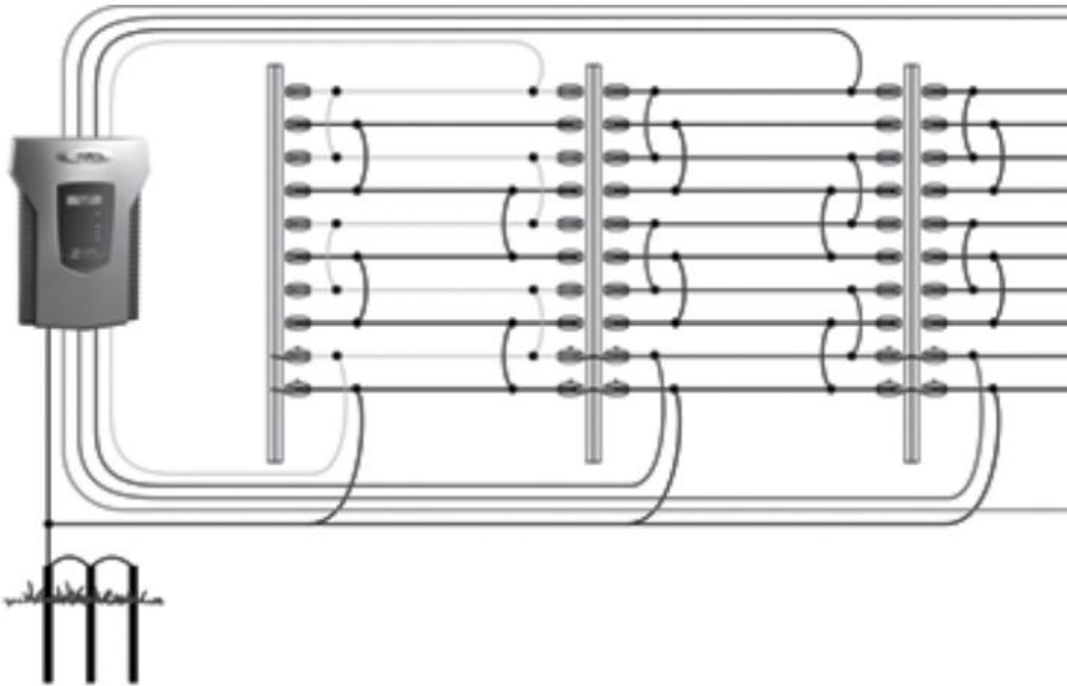

- Insulated wire woven through balustrade or chainmesh fencing; the alarm is given if the insulated wire is cut or shorted to earthed metal.

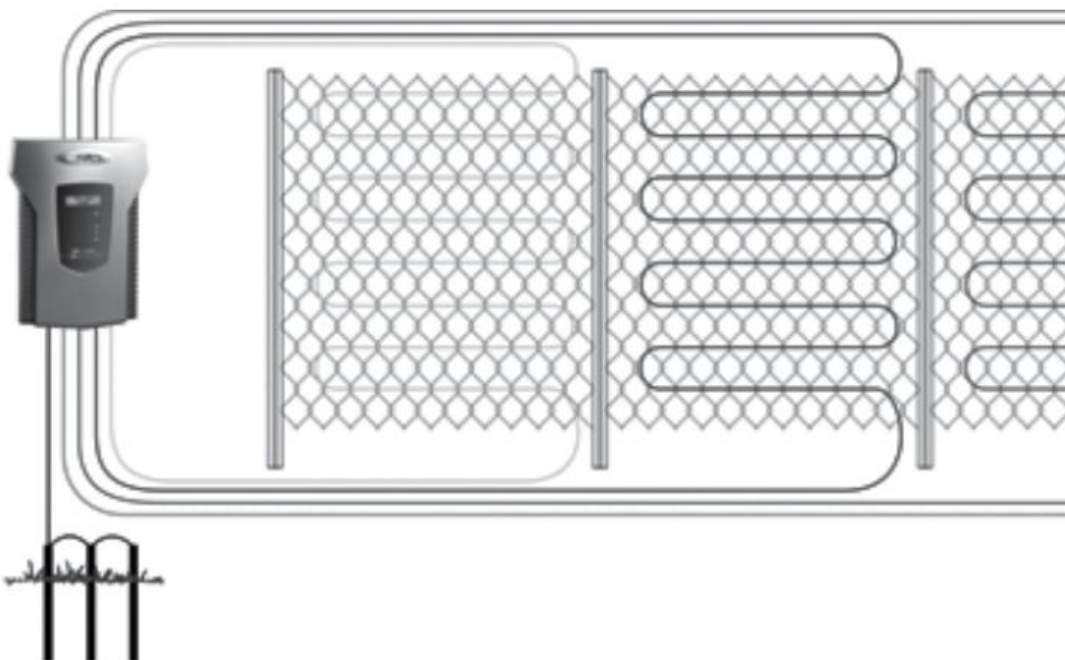

- Insulated wire buried underground; the alarm is given if the insulated wire is cut or shorted to earth.



Low Voltage Zoning System

The ZLM4 uses interleaved low voltage wires of the fence to detect any tampering.

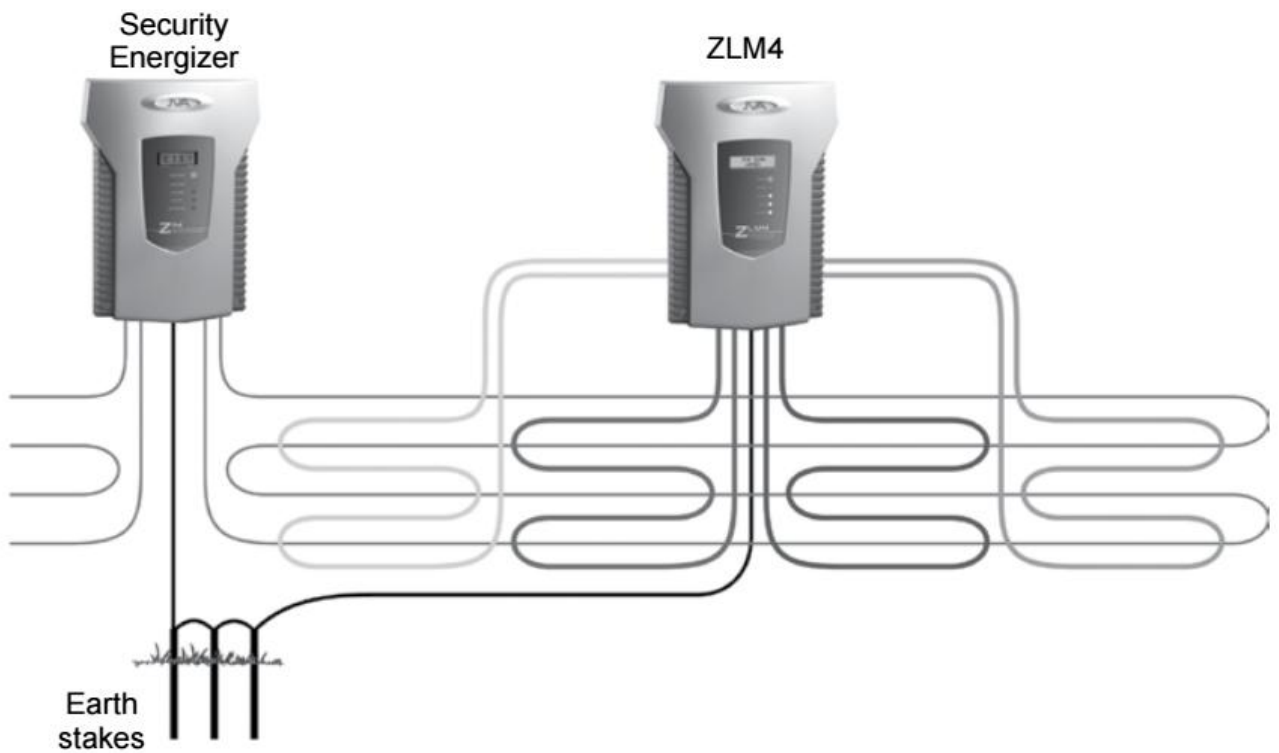

Interconnecting Wiring Diagrams

Combining the ZLM4 with a Z Series Energizer:

A ZLM4 can be combined with JVA Z series energizers to power the fence. The ZLM4 should be configured as a *slave* and the Z series energizer as the *master*. The number of Z series energizers and ZLM4 is limited by the available ID numbers if using the keypad bus. It is unlimited if using TCP/IP.

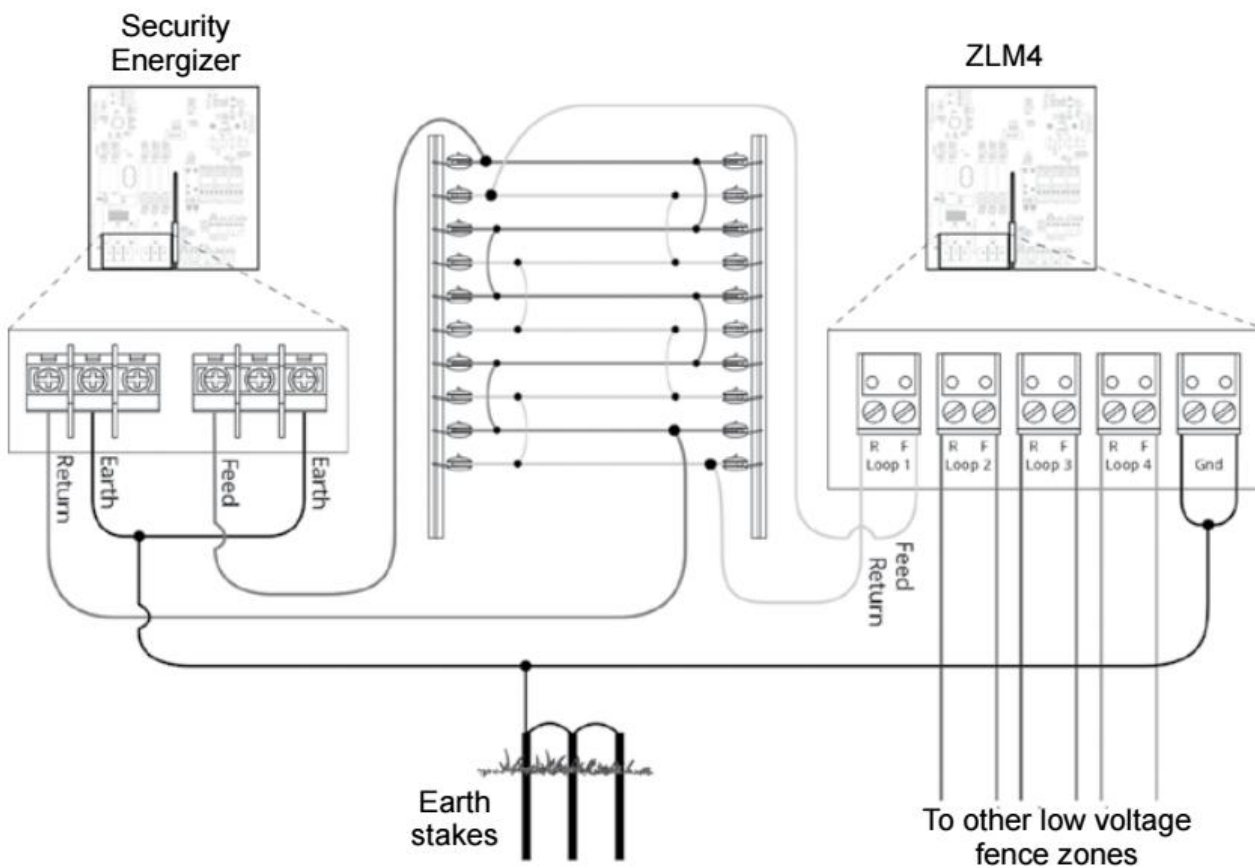

Keypad Bus Wiring

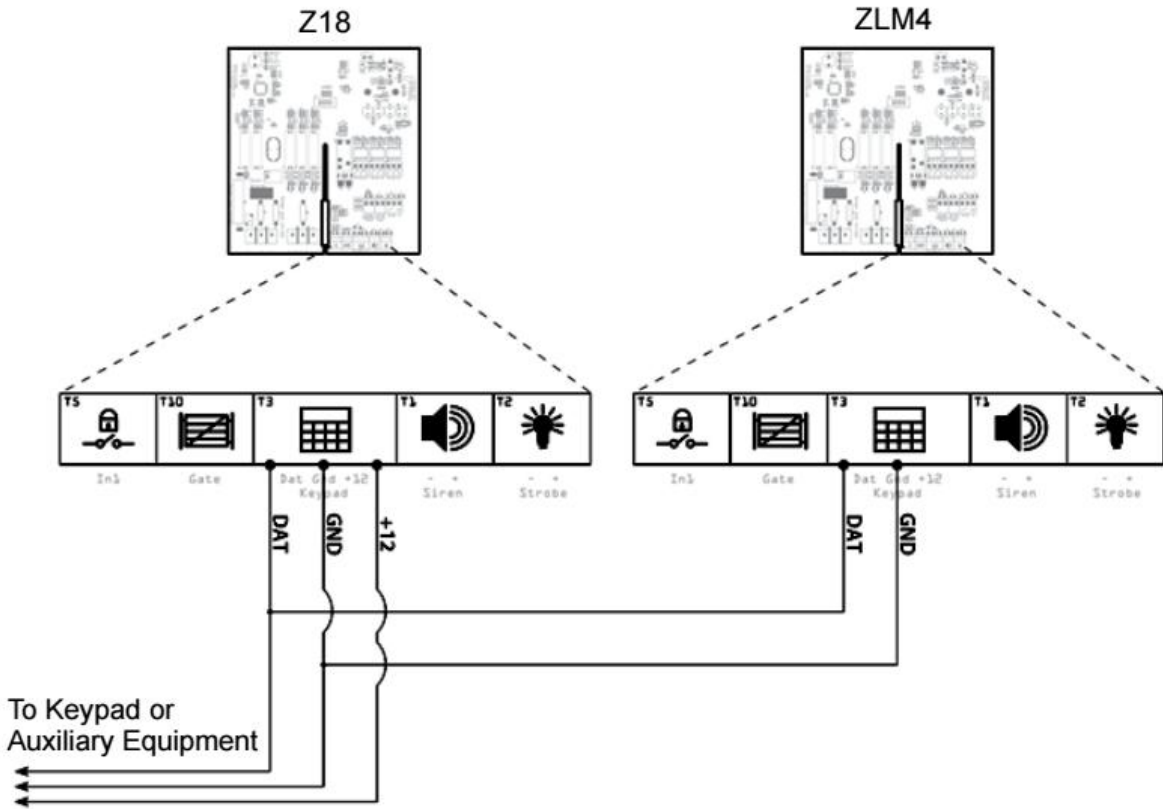

- Set the Group ID of the Z14 or Z18 to *Master* (2601#)
- Set the Group ID of the ZLM4 to *Slave 1* (2602#)

The Group ID of the ZLM4 must be 1 value higher than the Group ID of the Z-Series energizer driving it.

A ZLM4 by itself does not require the Group ID to be configured as it is factory set to Standalone Mode.

Example Group Wiring Diagrams

Z28 and two ZLM4 connected to Perimeter Patrol through a USB Interface PAE223:

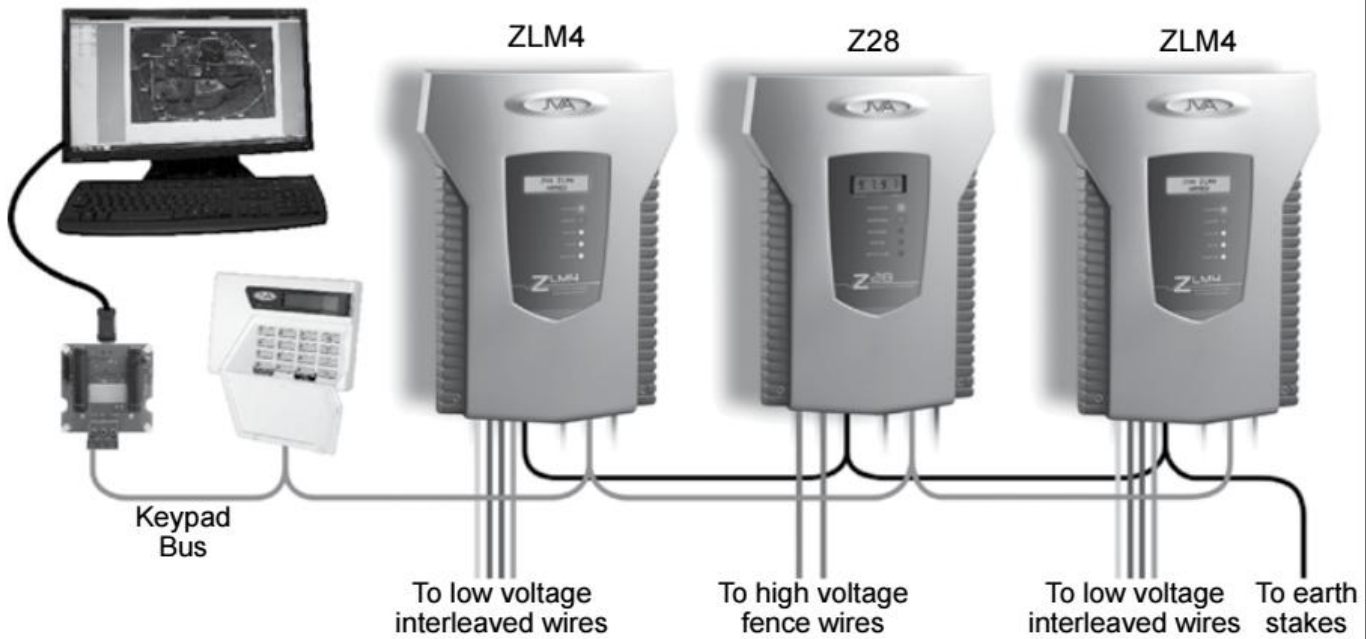

- Set the Group ID of the Z28 to *Master* (2601#)
- Set the Group ID of the first ZLM4 to *Slave 1* (2602#)
- Set the Group ID of the second ZLM4 to *Slave 2* (2603#)

PROGRAMMING OPTIONS

Like the Z series of security energizers, the ZLM4 has non-volatile memory in which programming options (or setup parameters) can be stored. These are factory pre-set (defaults), but can be field programmed using a keypad.

Enter Programming Mode

To enter programming mode, enter the 6 digit installer **PIN** followed by ***0#** keys. The keypad will beep twice to indicate that the command was accepted. If the PIN was incorrect the keypad will beep 3 times. The LCD on the ZLM4 will now show the first programming option and its current setting.

Pressing the **#** key will cycle through all the options on the LCD.

NOTE:

1. Not all numbers are used.
2. The **Default Installer PIN** is **012345**
3. Also see a table of ZLM4 Relevant Keypad Codes which are in the Operation section of this manual.

To Exit Programming Mode

To exit programming mode press ***#**. If left unattended the ZLM4 will time out and auto exit after approximately 5 minutes.

Changing the Installer PIN

The installer PIN may be changed only while in programming mode.

To enter a new installer pin, press **00** followed by the new 6 digit **PIN**, then the **#** key.

If you cannot remember your installer or user PIN, return the ZLM4 memory to default. To do this, remove power (AC off and disconnect the battery), open the ZLM4 enclosure, remove jumper J4 and reconnect the battery for about 10 seconds. Re-fit J4.

This will return all options to the factory set defaults.

Changing an Option

The options have possible values in the range of 0 to 99. Some are limited to lower maximum values.

To change an option value, first check the option number (see table on the following page) and then the table of values for that option. On the keypad, press the option number followed by the required value.

For example, to change option 1 to the maximum press 0199#, the keypad will beep twice to indicate that the command was successful. The energizer LCD will immediately show the updated value.

NOTE: As the keypad bus is common to a group of Z-Series energizers and ZLM4s, one keypad could be used to program all connected units at the same time. A Group containing Z-Series energizers and ZLM4s **MUST NOT** be programmed this way as the ZLM4 contains different Option values to the Z-Series energizers. Each ZLM4/energizer will need to be isolated from the Group Wiring and programmed individually.

Programmable Options Table

Option	Function	Default	Description
01	Voltage alarm level zone 1	20V	Sets the voltage below which the fence alarm will occur: if the return voltage falls below this level for more than the Missed pulse count a fence alarm (zone 1) will occur.
02	Voltage alarm level zone 2	20V	As above
03	Voltage alarm level zone 3	20V	As above
04	Voltage alarm level zone 4	20V	As above
05	Not used	0	
06	Missed Pulse Count	3	Sets the number of pulses which may be missed before the alarm is activated
07	Battery Alarm Voltage	2 (10V)	Sets the battery voltage threshold below which the general alarm will activate
08	Siren On Time	4 (3 Mins)	Sets the time that the siren (and keypad beeper) will stay on after an alarm
09	Siren Off Time	4 (10 Min)	The amount of time the siren will be off for after the on time has expired
10	Siren Cycles	3	The number of times the siren will sound for the time set in <i>On Time</i> above; after this many cycles the siren will automatically mute
11	Input type	0 (N/O)	Allows the control inputs to be changed from normally open to normally closed.
12	Input 2 Function	0	Gate switch
13	Gate Delay	2 (1 Min)	Gate switch open time till alarm
14	Chime Mode	2 (siren)	Allows the keypad and internal beeper function to be altered



Option	Function	Default	Description
15	Not Used	0	
16	Binary Options	0	Miscellaneous options
17	Not Used	0	
18	Not Used	4	Can be reduced if you are not using all 4 LV Zones to permanently bypass the unused zones
19	Not used	0	
20	Auto Rearm Time	0	Sets the time which must elapse after an alarm has timed out (completed the siren cycles) before the unit will automatically re-arm ready for the next alarm event
21	Relay 1	8	Used to assign an alarm function to relay 1 (siren output)
22	Relay 2	9	Used to assign an alarm function to relay 2 (strobe output)
23	Relay 3		Used to assign an alarm function to relay 3 (Zone 1 alarm)
24	Relay 4		Used to assign an alarm function to relay 4 (Zone 2 alarm)
25	Relay 5		Used to assign an alarm function to relay 5 (Zone 3 alarm)
26	Group ID	0	If used as part of a group, this sets the device ID
27	Relay 6		Used to assign an alarm function to relay 6 (Zone 4 alarm)

Programming Options in Detail

Zone 1 Fence Voltage Alarm Level (01xx#)

This option sets the voltage below which the zone alarm will occur. If the fence voltage measured at the return 'R' loop terminal falls below this level for more than the *Missed Pulse Count*, a fence alarm (zone 1) will occur. The value is set directly, not via a table.

For example, to set a threshold of 25V enter: 0 1 2 5 #
Setting this option to 0 effectively turns off fence voltage monitoring.

Warning: Setting this level to higher than the normal running voltage of the fence will result in continuous fence alarms.

Value (x)	Alarm Level
Minimum	
0	0.0 V
Default	
20	20V
Maximum	9.5 V
40	40 V

Zone 1 Fence Voltage Alarm Level (01xx#)

Zone 2 Fence Voltage Alarm Level (02xx#)

As above for zone 1

Zone 3 Fence Voltage Alarm Level (03xx#)

As above for zone 1

Zone 4 Fence Voltage Alarm Level (04xx#)

As above for zone 1

Missed Pulse Count (06xx#)

This option enables the pulse count to be varied from the default (3). This is the number of bad or missing pulses that are counted before the alarm occurs.

The value is set directly. For example to set a threshold of 2 bad or missing pulses enter:

0 6 0 2 #.

NOTE: The lower this option is set the more likely you are to get false alarms.

Value (x)	Missed Pulses
0	1
1	1
2	2
3	3
4	4
5	5
6	6
7	7
8	8
9	9

Missed Pulse Count (06xx#)

Battery Alarm Voltage (07x#)

This option sets the battery voltage threshold below which the general alarm will activate. The default *Battery Alarm Voltage* is 10.0 Volts. This alarm can be set to activate one of the relays, and is part of the general alarm.

Value	Alarm
0	9.0 V
1	9.5 V
2	10.0 V
3	10.5 V
4	11.0 V
5	11.5 V
6	12.0 V
7	12.5 V
8	13.0 V
9	13.5 V

Battery Alarm Voltage (07x#)

Siren On Time (08x#)

This option sets the duration of time that the siren will remain on after a fence alarm occurs. After this time the siren will turn off for the *Siren Off Time* indicated in the table. The siren will sound again if the alarm is still present after this off time has passed.

The default is 3 Minutes. This may be the subject of local regulations to stop an alarm causing undue disturbance to neighbours, etc.

NOTE: The *Siren On Time* will be cut short if the battery falls below the low battery level.

Value	Time
0	10 Seconds
1	30 Seconds
2	1 Minute
3	2 Minutes
4	3 Minutes
5	4 Minutes
6	5 Minutes
7	6 Minutes
8	7 Minutes
9	8 Minutes

Siren On Time (08x#)

Siren Off Time (09x#)

This option sets the amount of time the siren will be off for after the *Siren On Time* has expired. If an alarm is still present after this off time the siren will sound again.

Value	Time
0	10 Seconds
1	1 Minute
2	2 Minute
3	5 Minutes
4	10 Minutes
5	20 Minutes
6	30 Minutes
7	40 Minutes
8	50 Minutes
9	60 Minutes

Siren Off Time (09x#)

Siren Cycles (10x#)

This option sets the maximum number of times the siren will sound for the *On Time* if the alarm continues. This may be limited by local regulations to stop an alarm causing undue disturbance to neighbours etc.

NOTE: This is the maximum number of cycles for 1 continuous alarm; intermittent alarm events could cause more than this number of siren soundings.

The value is set directly. For example to 2 siren cycles enter: 1 0 2 #.

The default is 3, minimum is 1 and the maximum is 9.

Value	Cycles
0	1
1	1
2	2
3	3
4	4
5	5
6	6
7	7
8	8
9	9

Siren Cycles (10x#)

Input Type (11x#)

The control inputs can be inverted unless an input is used for a Gate switch, in which case it is always N.C.

Value (x)	Input type
0	N.O. (Normally Open)
1	N.C. (Normally Closed)

Input Type (11x#)

Input 2 Function (12x#)

This input cannot be configured to anything other than a *Gate* input at this time.

Gate Entry/Exit Delay (13x#)

The gate switch must remain open for longer than the *Gate Entry/Exit Delay* before the gate alarm is triggered. If the switch closes within this time, the Gate timer is reset to the *Gate Entry/Exit Delay* value.

Value	Time
0	0 Seconds (immediate)
1	30 Seconds
2	1 Minute
3	2 Minutes
4	3 Minutes
5	4 Minutes
6	5 Minutes
7	6 Minutes
8	7 Minutes
9	8 Minutes

Gate Entry/Exit Delay (13x#)

Chime Mode (14x#)

This option allows the ZLM4 internal beeper and the keypad beeper to be used as a door chime for the gate switch.

When set to *None*, the keypad beeper is used to indicate correct keypad operation only.

When set to *Door Chime*, the beepers will sound when the gate switch opens, even if the energizer is disarmed.

Value	Function
0	None
1	Door Chime
2	Siren
3	Fence Alarm
4	Gate beeps plus Siren

Chime Mode (14x#)

NOTE: *Gate* must be selected in Input 2 Function (Option 12).

If set to *Siren*, the beepers mimic the siren function.

Gate Beeps plus *Siren* will give 2 beeps on *Gate Open* and 4 on *Close*, plus continuous for an alarm. Beeps are on the keypad only, not on the internal beeper.

Fence Mode (15x#)

Not currently implemented – for future use.

Binary Options (16x#)

Each option in this table can be turned on by adding the value.

For option +1 set 16 to 01; for +1 and +2 set 16 to 03.

+1: Disable Proximity switch. The magnetic reed switch on the display board will be disabled.

+2: Enable Siren Acknowledge. The siren will chirp once for armed and twice for disarmed.

Value	Function
0	None
+1	Disable Prox. switch
+2	Siren codes

Binary Options (16x#)

Zones (not yet implemented)

This option sets the number of zones the ZLM4 will monitor. This will reduce the amount of unnecessary information that will be displayed if you are only monitoring one zone.

Value	Function
0	None
1	One Zone
2	Two Zones
3	Three Zones
4	Four Zones

Zones

Auto Re-Arm Time (20x#)

This option sets the time which must elapse before another alarm will sound after the first alarm has timed out (gone completely through its cycles).

If an event occurs which triggers the siren, any other events which would otherwise trigger the siren (such as a gate alarm) will be ignored while the siren is sounding and until after the *Auto Re-Arm* time has passed.

A setting of 9 will disable *Auto Re-Arm*.

The default is 0 seconds (immediate).

Value	Function
0	0 Seconds (immediate)
1	30 Seconds
2	1 Minutes
3	2 Minutes
4	3 Minutes
5	4 Minutes
6	5 Minutes
7	6 Minutes
8	7 Minutes
9	Disabled – Do not auto re-arm

Auto Re-Arm Time Values

Relay Functions

All relays can be set to any of the available functions (user assignable).

Relay 1 is (21x#)

Relay 2 is (22x#) etc

NOTE: Relay 6 is (27x#)

The defaults for the ZLM4 are:

- Relay 1 – Siren (8)
- Relay 2 – Strobe (9)
- Relay 3 – Zone 1 Alarm (0)
- Relay 4 – Zone 2 Alarm (1)
- Relay 5 – Zone 3 Alarm (2)
- Relay 6 – Zone 4 Alarm (3)

NOTE: The siren and strobe switched 12V outputs can be used to drive external buffer relays.

Value (x)	Mode
0	Zone 1 alarm
1	Zone 2 alarm
2	Zone 3 alarm
3	Zone 4 alarm
4	Armed
5	Un-used
6	Un-used
7	General
8	Siren
9	Strobe
10	AC Fail
11	Low / Bad Battery
12	Un-used
13	Un-used
14	Gate Alarm
15	Siren caused by Gate Alarm

Relay Function Values

Function	Logic for Alarm State (opposite of normal state)
Zone X Alarm	The ZLM4 is Armed AND any zone alarm occurs; these include: <ul style="list-style-type: none"> • The loop return Voltage has fallen below the Fence Voltage Alarm Level (Low Voltage) • High voltage has been detected (shorted to high voltage wires) for more energizer pulses than the Missed Pulse Count setting. This function is not latched.
Armed	The ZLM4 is Armed
General	AC Fail OR Tamper OR Low Battery OR Gate Alarm OR Internal Error. Latched for internal errors only.
Siren	Fence Alarm OR Gate Alarm OR Tamper. This will time out after the <i>Siren Time Out</i> time. This function is latched.
Strobe	As per Siren but does not time out, will remain on until both channels are switched off. This function is latched.
AC Fail	Alarm on AC Fail
Battery	Alarm on low or bad battery

Relay Options Explained

Group Mode (26x#)

A group must have only 1 master. The other energizers/ Monitors in the group are slaves.

The correct procedure is:

Connect the keypad to each energizer/ZLM4 in turn, programming each Option as required before linking the keypad bus into a group.

The ZLM4 should only be a group master if there are no Z energizers in the group. i.e. The group is made up of one or more ZLM4's only.

If a PAE212 TCP/IP adaptor is used, it is the group master. All other devices should be set to slaves.

All energizers must be synchronised, therefore non-synchronised agricultural energizer must never be used in a system with a ZLM4. This allows the ZLM4 pulses to be synchronised with other ZML4s or Z-Series energizer.

Value (x)	Mode
0	No Group
1	Master
2	Slave 1
3	Slave 2
4	Slave 3
5	Slave 4
6	Slave 5
7	Slave 6
8	Slave 7
9	Slave 8
10	Slave 9
11	Slave 10
12	Slave 11
13	Slave 12
14	Slave 13
15	Slave 14

Group Mode (26x#)

Keypad Programming

Changing the Keypad Messages and Address

The messages and each of the 15 zone labels can be changed.

The Dealer Message displays when the system is on standby.

Zone Labels display after the [#] key is pressed during alarm memory or faults.

The programmable Service Message is displayed during AC failure, communication failure, or low battery.

Keys Used for Changing Messages:

[1]	[2] Character up	[3] not used	Emergency not used
[4] ← Cursor left	[5] Next Message	[6] → Cursor right	Fire not used
[7]	[8] Character down	[9]	Panic not used
[*]	[0] Last Message	[#] Enter/Exit	Bypass not used

- To activate the keypad programming mode, enter the [Installer's Code] [*][0][1][#]. Information may be entered into the keypad in the form of letters (upper and lower case), numbers (0 – 9), and 22 special symbols. All characters are displayed in the order: upper and lower case letters, numbers, and special symbols. The [Space] character precedes the letter A.
- To enter a Label, use the [2] key to scroll through the characters until you reach the desired character. If you scroll past the desired character, the [8] key may be used to scroll backwards. **NOTE:** the space character is before the A character (When A is displayed, press [8] to get a space).
- When the desired character is displayed, press the [6] key to move the cursor to the next character position. The [4] key moves the cursor to the left.
- When all characters have been entered, press the [#] key to enter the message and move to the next message position.
- Use the [0] key to move backward through the messages.
- To change the keypad address, scroll through the messages until the keypad displays: *Keypad address* __, then change the value by pressing [2] (up) or [8] (down). Validate by pressing [#].

NOTE: If you move to the next message using [5] instead of the [#] key you will lose any changes you made!

The message order is:

- *SERVICE MESSAGE* (Displayed under 'System Trouble')
- *DEALER MESSAGE* (Displayed under the standby message: 'Ready to Arm')
- *ZONE NAMES*
- *BAUD RATE* (should be left at 2 400)
- *KEYPAD ADDRESS* ((should be left at 1)

To Exit Keypad Programming

When you have finished programming, press [*] [#].

NOTE: The keypad will also exit the programming mode if you do not press any key within a five minute period.

To return the keypad to default settings press the  emergency button during power up. This feature was added in keypad firmware version 1.2.

Connecting Multiple Keypads to a System

Up to three keypads may be used to remotely monitor and control the Z series security energizers.

To operate correctly, each keypad must be configured to use a unique Keypad Address. This is best achieved by connecting one keypad (at a time) to the master energizer and updating the Keypad Address. Once all keypads have a different address, all can be connected to the system. A recommendation is that one keypad is kept at *ADDRESS 1*.

The energizer now needs to be introduced to all of these keypads. This is achieved by resetting the energizer using the keypad (configured to *ADDRESS 1*), by pressing [USER PIN]*68#. Alternately the power can also be removed to reset the energizer. After a reset, the energizer will determine what keypads are connected, and only these Addresses will be used in the future. This prevents unauthorised keypads being added to the system once it is running.

If the security system is to use a PC based interface such as Perimeter Patrol, *KEYPAD ADDRESS 2* should not be used by a keypad. The PC software uses this address to control the energizers.

Notes Regarding Keypad Configuration

Zone 1 (the master) must be connected to the group. If it is not connected the other energizers in the group will not send status packets to the keypad. The status packets contain voltage and alarm information which the keypad displays. If *Zone 1* is not connected, the keypad will report a communications failure with all the zones.

A slave energizer disconnected from the group will only talk to a keypad if it has a Keypad Address of 1. When adding/removing an energizer to/from the group, be sure to re-analyse the group using the key sequence *68#. *Zone 1* (the master) must be connected to the group for this operation to work.

When re-analysing a group ensure all energizers are disarmed. If they are not this function will not work properly.

NOTE: If the group ID has recently been changed you may need to reset ([PIN]*68#) before the new IDs will be properly reported to the keypad.

INSTALLER DETAILS
Name
Tel.
Date of Installation

CUSTOMISED CODES
Customer PIN No.
Installer PIN No:



WARRANTY

All JVA products carry a **2-year warranty** against defective components and workmanship. The warranty excludes damage caused by acts of Nature such as lightning or flooding, power supply surges, rough handling, malicious actions or incorrect wiring.

Whilst every effort has been made to check that the information contained is accurate, JVA Technologies Pty Ltd will not be liable to loss or damage resulting from construction, operation or failure of any installation or system. Installation of security electric fences should be made by trained professionals with regard to the relevant local standards and workplace health and safety requirements.

Product Model purchased: Serial No:

Customer Name:

Address:
.....
.....

Postal Code:

Tel. No: Cell: Landline:

email:

Date purchased: Invoice No:

Dealer Name:

Dealer's Stamp



Mail to your local JVA Dealer:

**RSA JVA Service Department P.O. Box 13898,
Cascades 3202, Republic of South Africa • [support @jva-fence.com](mailto:support@jva-fence.com)**

Warranty



JVA ELECTRIC FENCE SYSTEMS

JVA products are designed by JVA Technologies, Queensland, Australia and distributed to:



JVA RSA SERVICE CENTRES

Bloemfontein

36 Kolbe Lane
Tel: 051 448 6695

Cape Town

Unit 15, Viking Business Park
Viking Way, Epping Industria
Tel: 021 534 5056

Centurion

74 Cantonments Road, Lyttleton
Tel: 012 644 0201

Durban North

Shop 11, Arcadia Centre
87 Umhlanga Rocks Drive
Tel: 031 563 0274/6478

East London

Shop 3, Paphos Park
Devereaux Avenue
Tel: 043 726 6652/60

East Rand (Jet Park)

Aerostar Business Park
219 Jet Park Road, Jet Park
Tel: 011 397 3507

George

Shop 3, 57 York Road
George
Tel: 044 874 0669

Kimberley

29 Schmidtsdrift Road
Tel: 053 861 5631

Nelspruit

D1 Waterfall Park
15 Rapid Street
Riverside Industrial Park
Tel: 013 752 7152

North Rand (Kya Sand)

174 Bernie Street
Randburg
Tel: 011 708 6442

Pietermaritzburg

51 Winston Road
Tel: 033 342 6727

Pinetown

Unit 1, 7 Suffert Street
Tel: 031 702 6351

Polokwane

19A Suez Street
Nirvana
Tel: 015 292 6273

Port Elizabeth

45 Mangold Street
Newton Park
Tel: 041 365 7178

Pretoria

1185 Steve Biko Road
(977 Voortrekker Road)
Wonderboom South
Tel: 012 335 4290

Rustenburg

1 Howick Avenue, Shop 7
Waterfall Mall
Tel: 014 537 2884

Somerset West

Shop 4, Broadway Centre
Urtel Crescent
Tel: 021 851 1978

Upington

Upindustria Business Park
4 Progressus Street, Upindustria
Tel: 054 332 1458

Vanderbijlpark

5 Prime Business Park
Vanderbijlpark
Tel: 082 783 8449

West Rand (Roodepoort)

602 Ontdekkers Road
Delaréy, Roodepoort
Tel: 011 472 8823